

Description:

- Semi-precision bearing
- Full complement of balls
- 1664 lb. per roller load rating
- Hardened roller face
- Regreasable using pins as shown

Note: *Zero clearance between OAC and frame is required.*

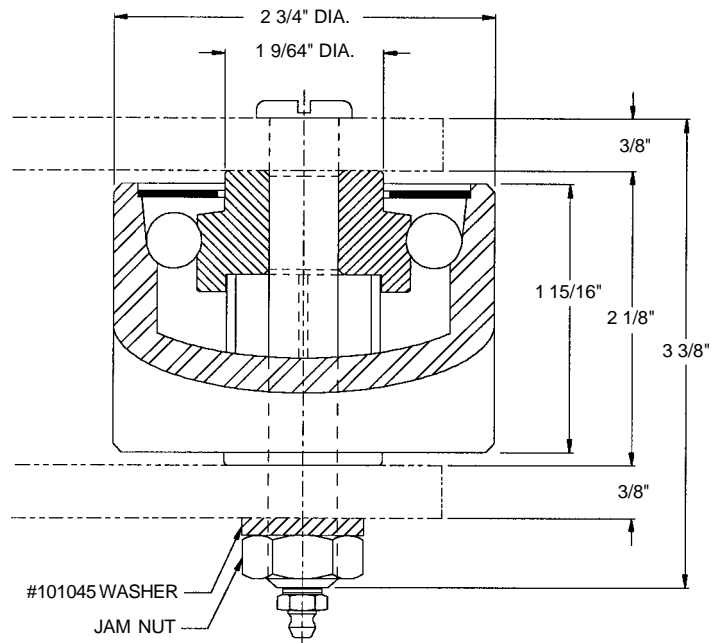

Roller No. 108018
with Pin No. 108020

Note: *Rollers and pins can be purchased separately.*

Description:

- Semi-precision bearing
- Full complement of balls
- 1664 lb. per roller load rating
- Hardened roller face
- Regreasable using pins as shown

Note: *Zero clearance between OAC and frame is required.*

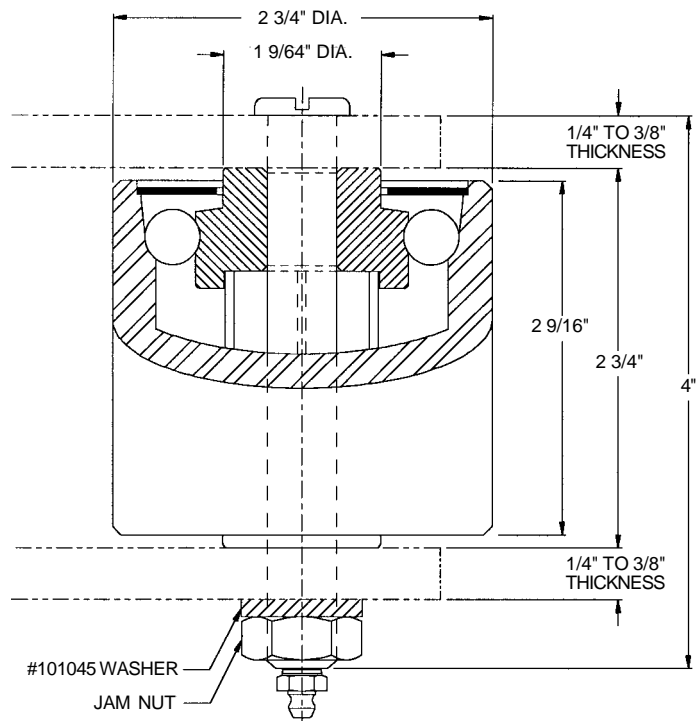

Roller No. 108019
with Pin No. 108021