

### Description:

- Flanged type non-precision bearing
- 145 lb. per bearing load rating
- Eleven 9/32 in. dia. hardened steel balls
- Pressed steel outer shell

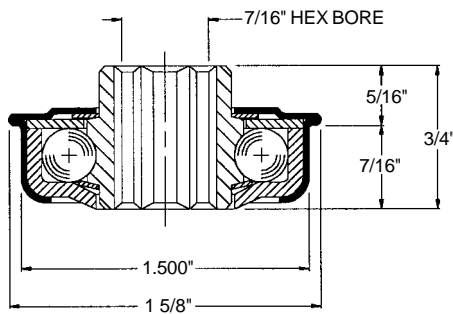

**Bearing No. 102053**

Front and Back Teflon Seal

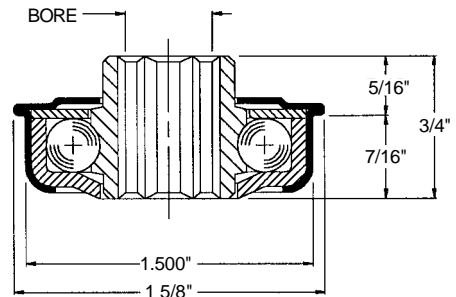

Bearing Number	Bore Size
102145	5/16" Hex
102180	3/8" Hex
102052	7/16" Hex
102181	1/2" Round

(0151, 1051, 2051, 0051, 3051)

### Description:

- Flanged type non-precision bearing
- 145 lb. per bearing load rating

- Eleven 9/32 in. dia. hardened steel balls
- Pressed steel outer shell

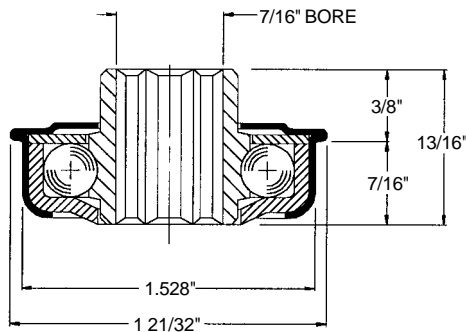

**Bearing No. 102031**

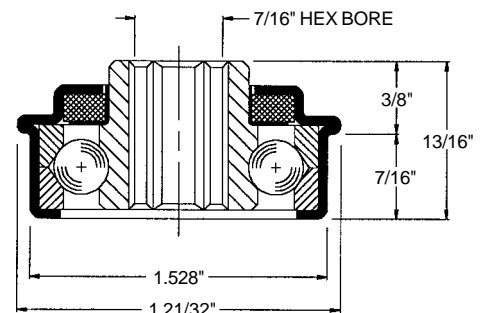

**Bearing No. 102072**

Front Felt Seal

(3092, 292)