



681

Combiner Section Ends

Sold as pairs. Section Ends can be bolted to the BeadWall or Roller Combiner frame.

Material: 10 ga. 304 stainless steel.

Part Number	Height (H)	Slot (A)	No. of Slots
VG-681-2	1.75	1.25	1
VG-681-3	2.75	.75	2
VG-681-4	3.75	1	2
VG-681-6	5.38	1.25	2

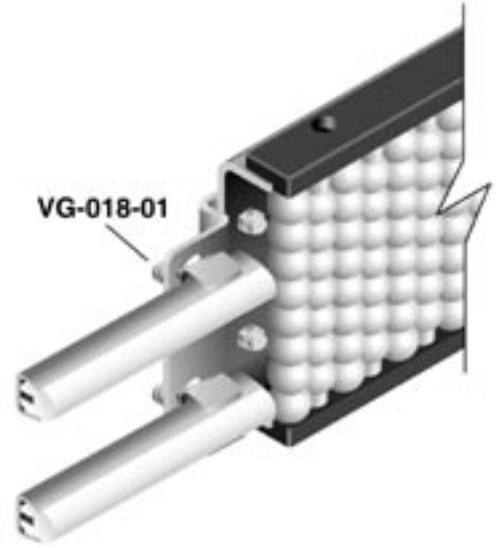
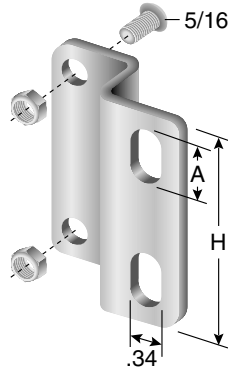
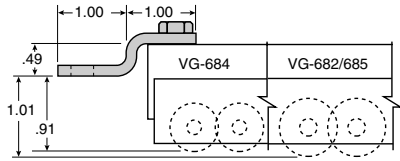

262

Ultra Heavy Duty Combiner Bracket

Easy, accurate, adjustable support for BeadWall or Roller Combiners up to 4" size. *Adjust while line is running.* All heavy duty stainless and noncorrosive parts.

Material: Stainless steel and ABS plastic knobs.

Part Number	Mounting Slot (in.)
VG-262-CS-53	2.65

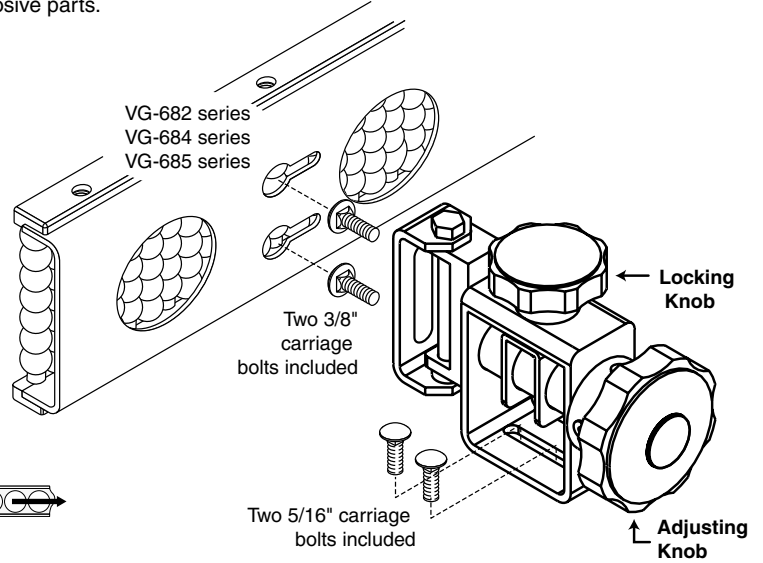
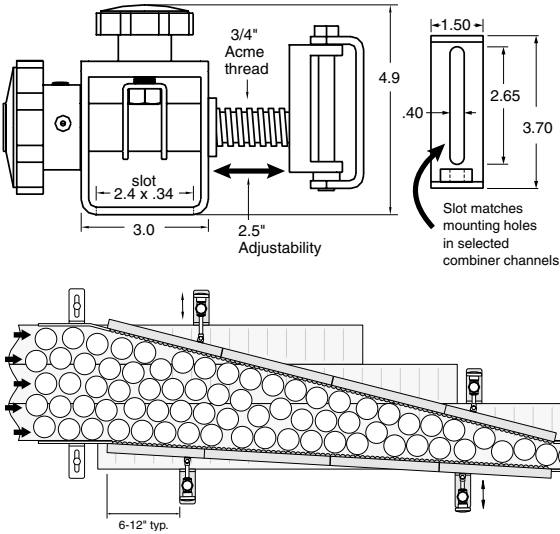

Bead and Roller Guides

205-G

Braced Angle Bracket

Heavy duty base for VG-262 combiner bracket. 1/4" thick stainless steel. Built-in angled brace for maximum support of heavy loads.

Material: 304 stainless steel.

Part Number
VG-205-G-14-S

