

ADVANTAGES IN DESIGN

Axles:

Manufactured from high quality stress proof cold rolled steel. Ends milled with flats to interlock in outside side bars.

Rollers:

Made from medium carbon steel and heat-treated for greater wear resistance.

Roller Bushings:

Roller bushings are made from tubing, not rolled. By using tubing, the bushing maintains more roundness, which creates a more even wear surface. Bushings are heat treated for increased wear resistance.

Welded Side Wings:

Welding the side wings to the pans keeps material from dropping through gaps between the wings and the pans. This feature reduces the amount of material allowed to migrate to the chain and tracks, which causes increased wear.

Side Bars:

Constructing the chain with inside and outside side bars results in the load being carried by the chain as opposed to applying pressure to the thru axles and pan loops, which occurs when side bars are eliminated. Greater belt pull capacity is achieved with the use of side bars. "D" style outside bars keep the milled end axles from wear caused by the "scrubbing" action that occurs when the chain goes through curves and around sprockets. This feature eliminates that area as a wear point.

DO ALL THESE THINGS MATTER?

Approximately 1/3 to 1/2 of the cost of a hinged steel belt conveyor is the cost of the belt. By using higher quality belting, you can expect increased belt life. Increased belt life saves you money and down time. Consider these things when buying your next belt:

- How often do I want to replace this belt?
- What is my actual cost when I compare cost to belt life?
- What is the cost of labor to replace the belt?
- What is the cost in lost production from down time?

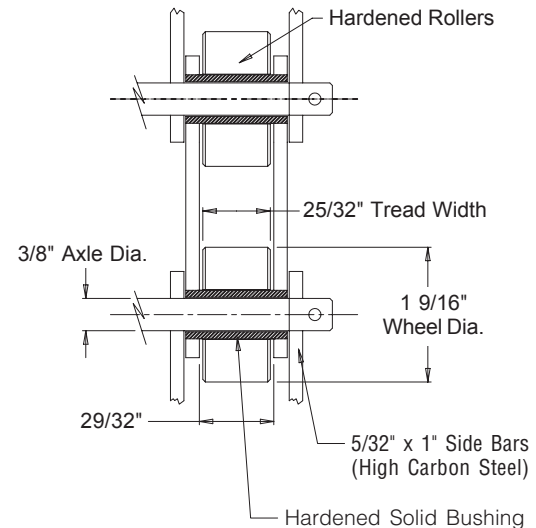

Wheel Cross Section

“W” Series - Welded Wing Belting Ordering Information

2P - 12 - D - 12.5

2 1/2" Pitch ————|————— Cleat Spacing
12" Belt Width ————|————— Pimples/Perforated Pans